

Planung und Montage

Beschlag für Holzschiebewände parallel zur Schiebeamse gestapelt.

Planification et montage

Ferrures pour cloisons coulissantes en bois, avec rangement parallèle à l'axe de coulissement.

Planning and installation

Hardware system for wooden sliding walls that are stacking parallel to the slide axis.

Pianificazione e montaggio

Ferramenta per porte scorrevoli in legno parcheggiate parallelamente all'asse di scorrimento.

Planificación y montaje

Herraje para tabiques deslizantes de madera apilados paralelo al eje del deslizamiento.

■ Hawa Teile ■ Eléments Hawa ■ Hawa components ■ Componenti Hawa ■ Componentes Hawa

NOTICE: Metric dimensions are valid – dimensions stated in inches are for information only.

Diese Zeichnung ist Eigentum der Hawa AG und darf weder verwertet, vervielfältigt noch Dritten zugänglich gemacht werden. Alle unsere Katalog-Zeichnungen sowie die speziellen Einbauzeichnungen im Massstab 1:1 usw. stellen Beispiele zum Einbau unserer Beschläge dar. Irgendwelche Ansprüche aus der Verwendung dieser Unterlagen können durch den Kunden nicht abgeleitet werden. Für bau-/projektbezogene, konstruktive Details wird keine Verantwortung übernommen.

Ce plan est la propriété de Hawa AG. Il ne peut être utilisé à titre lucratif, ni photocopié ou transmis à un tiers. Tous les plans publiés dans les catalogues, les plans de montage spéciaux à l'échelle 1:1 etc. représentent des exemples de montage de nos ferrures. Le client ne peut tirer des droits quelconques en utilisant de tels documents. Pour des détails constructifs touchant aux projets ou aux sites, toute responsabilité est déclinée.

This drawing remains the property of Hawa AG and may not be sold, reproduced or made available to third parties. All of our catalogue drawings and special full scale installation drawings etc. represent installations using our hardware and fittings. No claims on the part of the customers can be considered which arise in connection with the use of these documents. For site or project-related design details any liability is declined.

Questo disegno è proprietà di Hawa AG e non può essere usato a scopo di lucro, riprodotto e reso accessibile a terzi. Tutti i nostri disegni del catalogo nonché i particolari disegni di montaggio in scala 1:1 ecc. rappresentano esempi per il montaggio delle nostre ferramenta. Eventuali rivendicazioni a seguito dell'utilizzo di questa documentazione non possono essere evidenziate da parte del cliente. Non assumiamo nessuna responsabilità per dettagli costruttivi che riguardano qualsiasi costruzioni o progetti.

Este documento es propiedad de la empresa Hawa AG. Se excluye la venta y reproducción, al igual que el acceso a terceras personas. Los planos contenidos en nuestros catálogos, al igual que los planos especiales de montaje a escala 1:1 etc. representan ejemplos para el montaje de nuestros herrajes. Su uso no implica la deducción de derechos, cualquiera sea su naturaleza, por parte del cliente. No asumimos ninguna responsabilidad por los detalles constructivos relativos a la construcción o proyectos.

<p>18337</p>	<p>f</p>	Gezeichnet/Dessiné/Drafted/Disegnato/Dibujado 04.2002 / STJ	Internationale Schutzrechte Änderungen vorbehalten Droits internationaux déposés Sous réserve de modifications Swiss and foreign patents Design subject to modification Diritti protettivi internazionali Con riserva di apportare modifiche Derechos internacionales protegidos Planos sujetos a modificaciones
		Änderung/Modification/Modification/Modifica/Modificación 04.2015 / RHU	
Ersetzt/Remplace/Replaces/Sostituisce/Reemplaza 18337e	Visum/Visa/Visa/Visto/Visado 07.2015 / MFR		

- a) 20.06.02 / MFR (2760)
- 10.07.02 / MFR (2779)
- b) 28.04.03 / WÜT (2921)
- c) 12.2005 / BKU (3519)
- d) 15.05.08 / MFR (4078)
- e) 06.12.10 / FuG (4615)
- f) 20140163

Deutsch

Hawa Aperto 60 H

Normstapelraum für 8 Schiebe- und 1 Drehtüre
Maximales Türgewicht 60 kg
Maximale Türhöhe 2600 mm
Minimale Türbreite 550 mm
Maximale Türbreite 1500 mm
Türdicke 35 – 50 mm

Spezialanlage Rücksprache mit Hawa Sliding Solutions AG

Français

Hawa Aperto 60 H

Espace de parcage standard p. 8 portes coulissantes et 1 porte pivotante
Poids maximum par porte 60 kg
Hauteur maximum par porte 2600 mm
Largeur minimum par porte 550 mm
Largeur maximum par porte 1500 mm
Epaisseur de porte 35 à 50 mm

Modèle spécial, veuillez consulter Hawa Sliding Solutions AG

English

Hawa Aperto 60 H

Standard parking area for 8 sliding doors and 1 pivot door
Maximum panel weight 60 kg (132 lbs.)
Maximum panel height 2600 mm (8'6 ³/₈"")
Minimum panel width 550 mm (1'9 ²¹/₃₂"")
Maximum panel width 1500 mm (4'11 ¹/₁₆"")
Panel thickness 35 to 50 mm (1 ³/₈" to 1 ³¹/₃₂"")

Special model, please consult Hawa Sliding Solutions AG

Italiano

Hawa Aperto 60 H

Parcheggio normalizzato per 8 porte scorrevoli e 1 porta girevole
Peso massimo della porta 60 kg
Altezza massima della porta 2600 mm
Larghezza minima della porta 550 mm
Larghezza massima della porta 1500 mm
Spessore della porta 35 – 50 mm

Impianto speciale, consultare la Hawa Sliding Solutions AG

Español

Hawa Aperto 60 H

Área de apilado normalizado para 8 paneles deslizantes y
1 puerta pivotante
Peso máximo del panel 60 kg
Altura máxima del panel 2600 mm
Ancho mínimo del panel 550 mm
Ancho máximo del panel 1500 mm
Espesores del panel 35 a 50 mm

En caso de instalaciones especiales consultar con
Hawa Sliding Solutions AG

Technische Änderungen vorbehalten
Sous réserve de modifications techniques
Subject to modification

Con riserva di apportare modifiche tecniche
Bajo reserva de modificaciones técnicas

Inhaltsverzeichnis

Inhaltsverzeichnis	3
1:1-Schnitt	4
Anlage-Typen	5
Berechnungen	6–9
Position Komponenten.	10/11
Position Bolzenriegelschloss mit Führungzapfen	12
Ausfräsungen Schiebetüren	13
Montage.	14–19
Beschlägeübersicht	20

Sommaire

Sommaire.	3
Coupe 1:1	4
Types d'installations	5
Calculs	6–9
Position des composants	10/11
Position de la serrure à pènes avec goujon de guidage	12
Découpages des portes coulissantes	13
Montage.	14–19
Composants de la ferrure	20

Contents

Contents	3
1:1-Cut	4
System types	5
Calculations	6–9
Position of components	10/11
Position of bar bolt lock with guide pin	12
Cutouts sliding doors	13
Mounting	14–19
Hardware system components	20

Indice

Indice	3
Sezione 1:1	4
Tipi sistemi	5
Calcoli	6–9
Posizioni dei componenti	10/11
Posizione serratura a chiavistello con perno di guida	12
Fresatura porte scorrevoli	13
Montaggio.	14–19
Assortimento ferramenta	20

Contenido

Contenido	3
Cortes 1:1	4
Tipos de sistemas	5
Cálculos	6–9
Posición de componentes	10/11
Posición cerradura de pasador con perno de guía	12
Fresados para paneles deslizantes	13
Montaje	14–19
Componentes de los herrajes	20

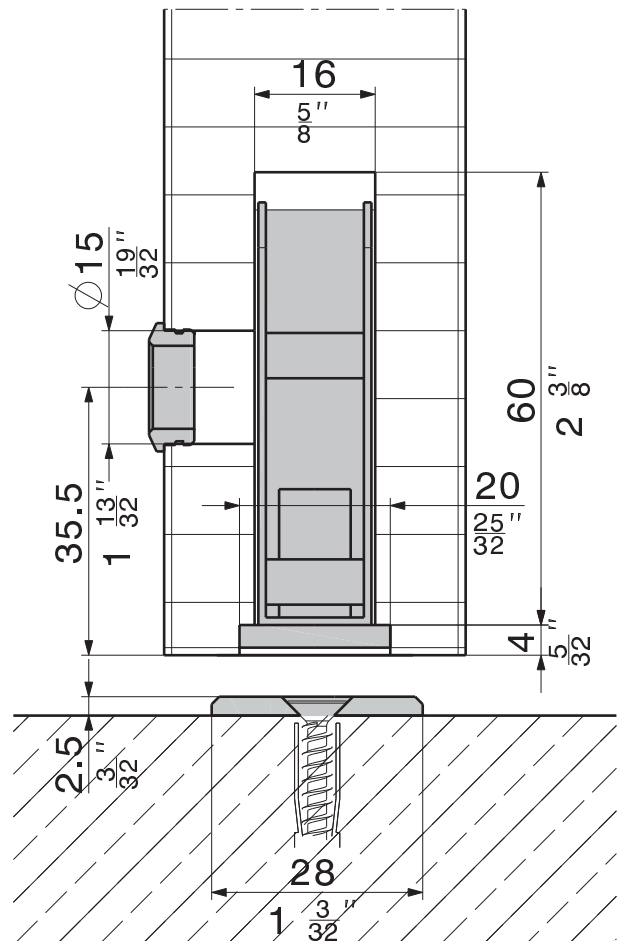
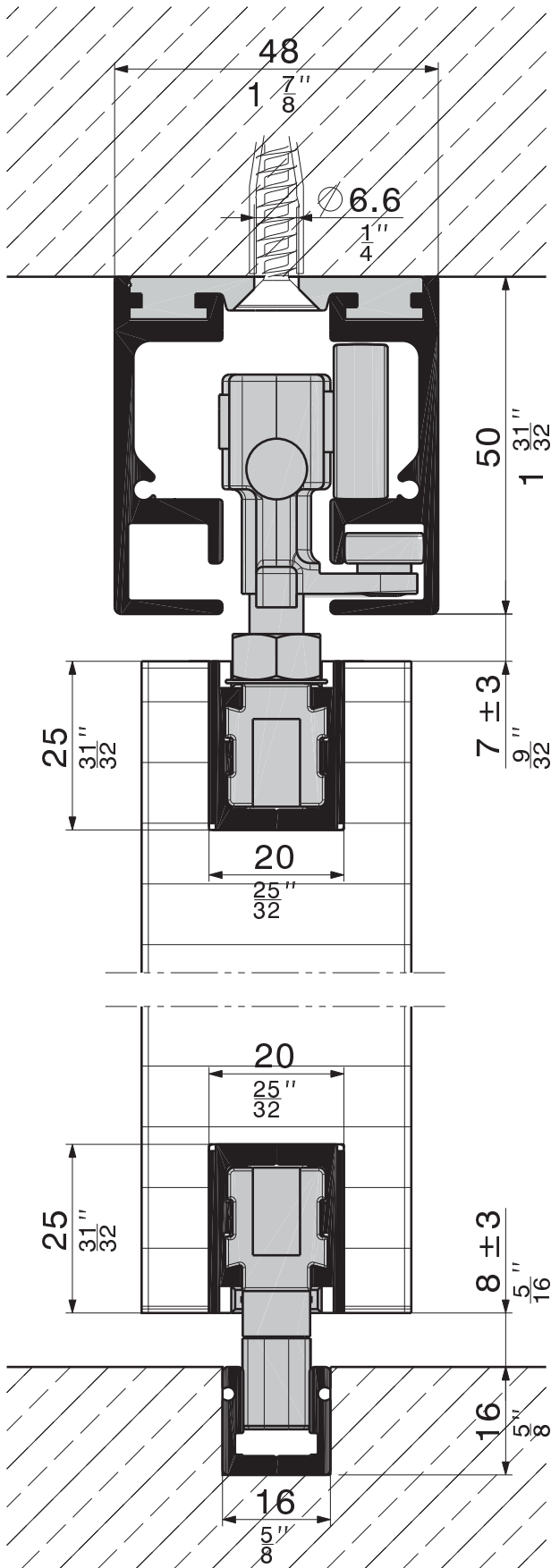

Technische Änderungen vorbehalten
 Sous réserve de modifications techniques
 Subject to modification

Con riserva di apportare modifiche tecniche
 Bajo reserva de modificaciones técnicas

Anlage-Typen
Types d'installations
System types
Tipi sistemi
Tipos de sistemas

Mit Führungsschiene
 Avec rail de guidage
 With bottom guide channel
 Con guida
 Con riel de guía

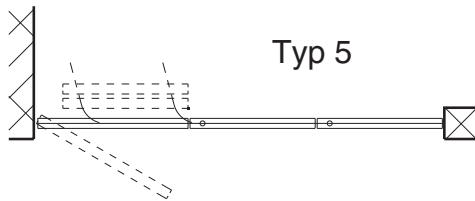
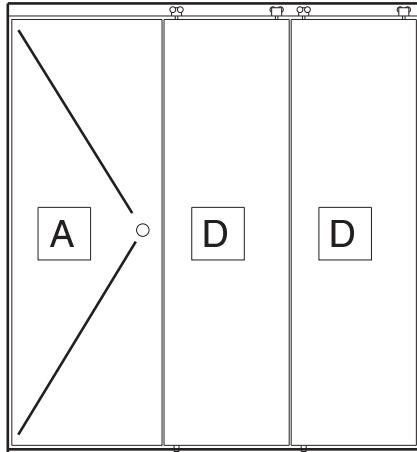

Typ 5

Ohne Führungsschiene
 Sans rail de guidage
 Without bottom guide channel
 Senza guida
 Sin riel de guía

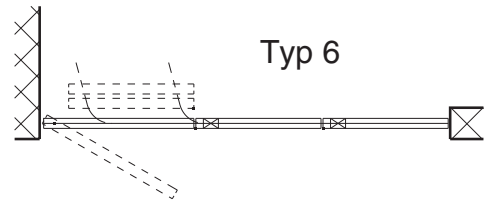
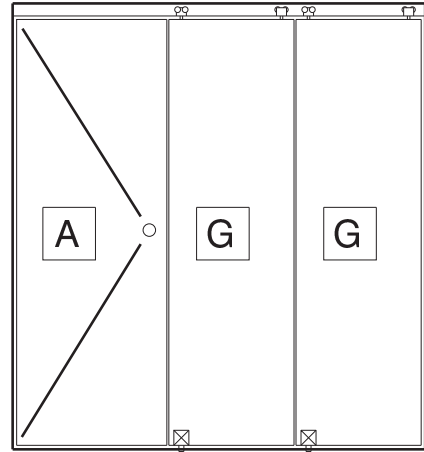

Typ 6

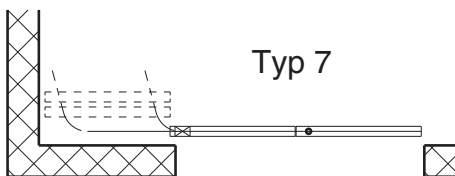
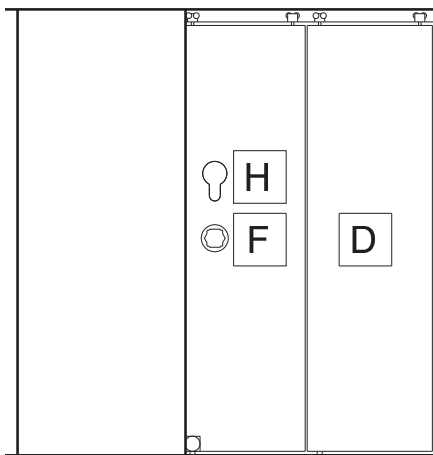

Typ 7

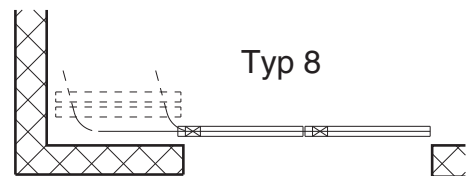
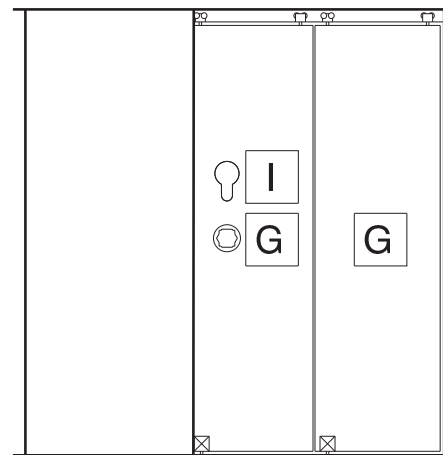

Typ 8

□ Bolzenriegelschloss mit Führungszapfen
 Serrure à pêne avec goujon de guidage
 Bar bolt lock with guide pin
 Serratura a chiavistello con perno di guida
 Cerradura de pasador con perno de guía

⊠ Bolzenriegelschloss
 Serrure à pêne
 Bar bolt lock
 Serratura a chiavistello
 Cerradura de pasador

Berechnungen ab Lichtmassbreite für Anlagen mit Drehtüren
Calculs à partir de la largeur intérieure pour installations avec portes pivotantes
Calculations as from the inside width for installations with pivot doors
Calcoli a partire dalla larghezza interna per costruzioni con porte girevoli
Cálculos a partir del ancho de luz para instalaciones con puertas pivotantes

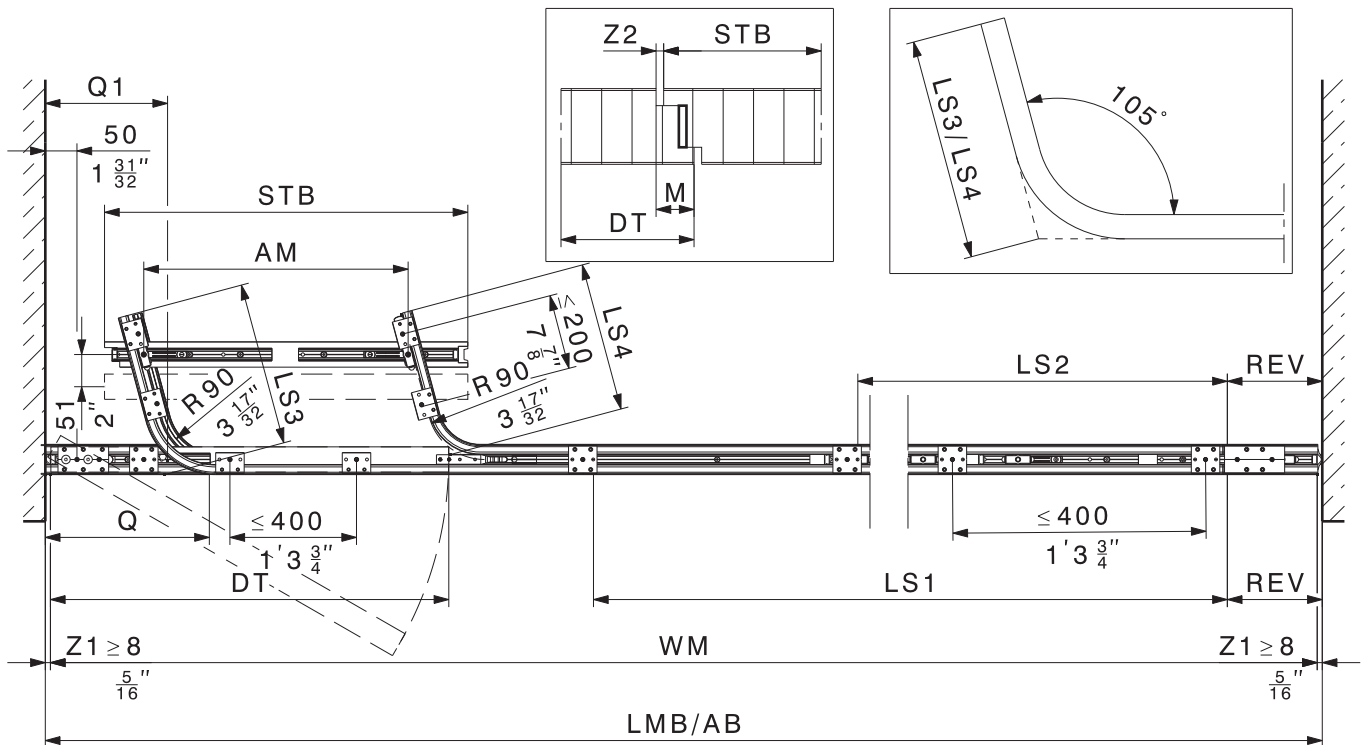

AT =	Anzahl Türen inkl. Drehtüre Nombre de portes, y compris porte pivotante Number of doors, including pivot door Numero porte, incl. porta girevole Número de paneles, incluido puerta pivotante
LMB =	Lichtmassbreite Largeur intérieur Inside width Larghezza interna Ancho de luz
STB =	Schiebetürbreite Largeur de la porte coulissante Sliding door width Larghezza porta scorrevole Ancho del panel deslizante
AM =	Achsmass Cote axiale Axial dimension Dimensione asse Dimensión de eje
LS =	Laufschiene Rail de roulement Top track Binario Riel de rodadura
M =	Falzmass Cote de feuillure Rebate dimension Dimensione incastro Dimensión de encaje
REV =	Laufschiene-Endstück Embout pour rails de roulement End-piece for top tracks Finecorsa binario Pieza final del riel de rodadura

Z1 =	
Z2 =	
REV =	150
AT =	
LMB =	
M =	

WM =	$LMB - (2 \times Z1)$	
STB =	$\frac{WM - 100 + Z2}{AT} - Z2$	
DT =	$STB + 100 + M$	
AM =	$STB - 73 - (AT \times 14)$	
Q =	$212 + (AT \times 14)$	
Q1 =	$Q - 68$	
LS1 =	$LMB - Q - 590 - REV$	
LS2 =	$LS1 - AM$	
LS3 =	$53 + (AT \times 51)$	
LS4 =	$LS3 - 25$	

Berechnungen ab Mass P für Anlagen mit Schiebetüren
Calculs à partir de la cote P pour installations avec portes coulissantes
Calculations based on dimension P for installations with sliding doors
Calcoli a partire dalla misura P per costruzioni con porte scorrevoli
Cálculos a partir de la dimensión P para instalaciones con paneles deslizantes

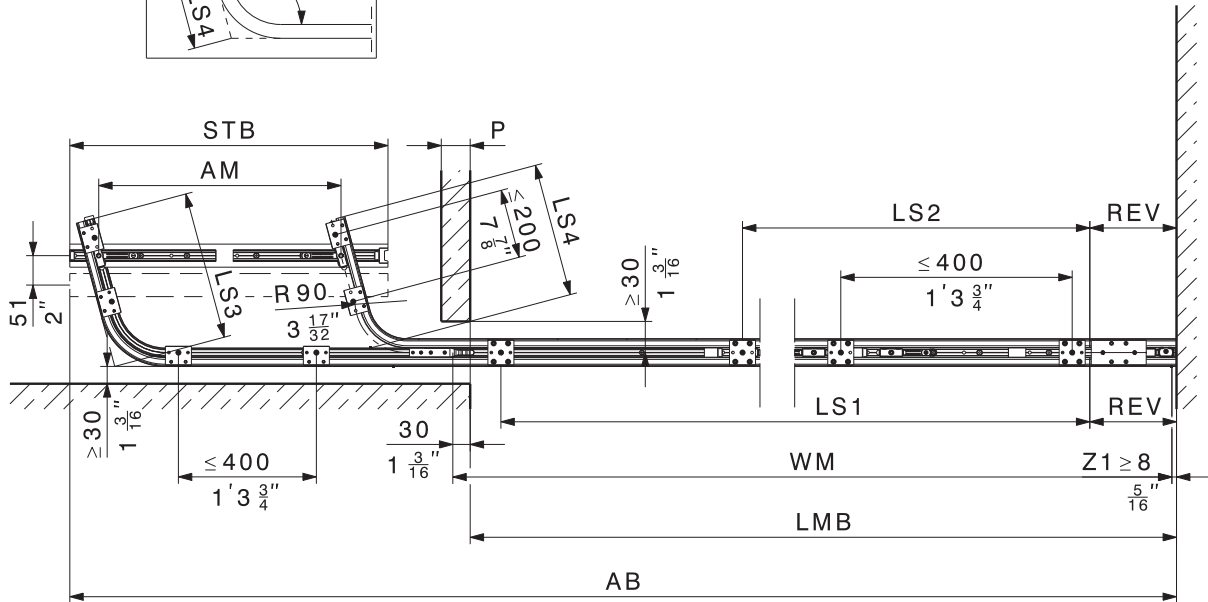
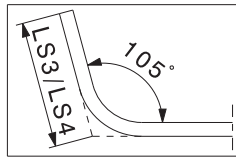

Z1 =	Luft Wand bis Türe Jeu entre mur et porte Clearance between wall and door Aria entre parete e porta Espacio entre muro y panel
Z2 =	Luft Türzwischenräume STB Jeu de l'espacement de porte STB Clearance of door interspace STB Aria intercedini porte STB Espacio intermedio ancho panel STB
ST =	Anzahl Schiebetüren Nombre de portes coulissantes Number of sliding panels Numero porte scorrevoli Número de paneles deslizantes
STB =	Schiebetürbreite Largeur de la porte coulissante Sliding door width Larghezza porta scorrevole Ancho del panel deslizante
REV =	Laufschienen-Endstück Embout pour rails de roulement End-piece for top tracks Finecorsa binario Pieza final del riel de rodadura
AM =	Achsmass Cote axiale Axial dimension Dimensione asse Dimensión de eje
LS =	Laufschiene Rail de roulement Top track Binario Riel de rodadura
AB =	Anlagenbreite Largeur d'installation Installation width Larghezza installazione Ancho de instalación

	P
REV =	150
Z1 =	
Z2 =	
ST =	
LMB =	
P =	

	P
WM =	LMB – Z1 + 30
STB =	$\frac{WM + Z2}{ST} - Z2$
AM =	STB – 86 – (ST x 14)
LS1 =	LS2 + AM
LS2 =	P + LMB – REV – 552 + (STx14)
LS3 =	(ST x 51) + 104
LS4 =	LS3 – 25
AB =	LMB + P + 64 + STB + (STx14)

Berechnungen ab Mass N für Anlagen mit Schiebetüren
Calculs à partir de la cote N pour installations avec portes coulissantes
Calculations based on dimension N for installations with sliding doors
Calcoli a partire dalla misura N per costruzioni con porte scorrevoli
Cálculos a partir de la dimensión N para instalaciones con paneles deslizantes

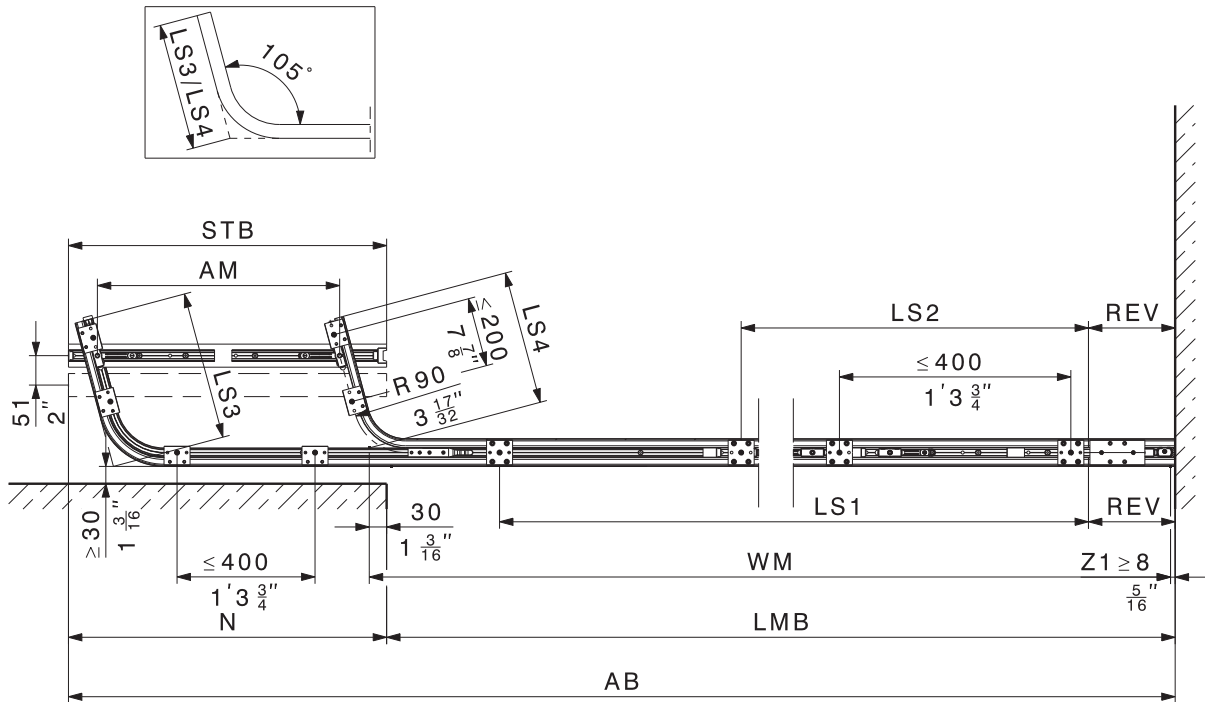

Z1 =	Luft Wand bis Türe Jeu entre mur et porte Clearance between wall and door Aria entre parete e porta Espacio entre muro y panel
Z2 =	Luft Türzwischenräume STB Jeu de l'espacement de porte STB Clearance of door interspace STB Aria intercapedini porte STB Espacio intermedio ancho panel STB
ST =	Anzahl Schiebetüren Nombre de portes coulissantes Number of sliding panels Numero porte scorrevoli Número de paneles deslizantes
STB =	Schiebetürbreite Largeur de la porte coulissante Sliding door width Larghezza porta scorrevole Ancho del panel deslizante
REV =	Laufschiene-Endstück Embout pour rails de roulement End-piece for top tracks Finecorsa binario Pieza final del riel de rodadura
AM =	Achsmass Cote axiale Axial dimension Dimensione asse Dimensión de eje
LS =	Laufschiene Rail de roulement Top track Binario Riel de rodadura
AB =	Anlagenbreite Largeur d'installation Installation width Larghezza installazione Ancho de instalación

	N
REV =	150
Z1 =	
Z2 =	
ST =	
LMB =	

	N
WM =	$LMB - Z1 + 30$
STB =	$\frac{WM + Z2}{ST} - Z2$
AM =	$STB - 86 - (ST \times 14)$
N =	STB
LS1 =	LS2 + AM
LS2 =	$LMB - REV - 36 - 580$
LS3 =	$(ST \times 51) + 104$
LS4 =	LS3 - 25
AB =	LMB + N

Berechnung Stapelraum-Innenverblendung, Führungsschiene
Calcul de cache intérieur pour espace de parcage, rail de guidage
Calculation of the stacking area inside covers, bottom guide channel
Calcolo zona di stipa-rivestimento interno, guida
Cálculo del área de apilado con perfil de cobertura a la vista, riel de guía

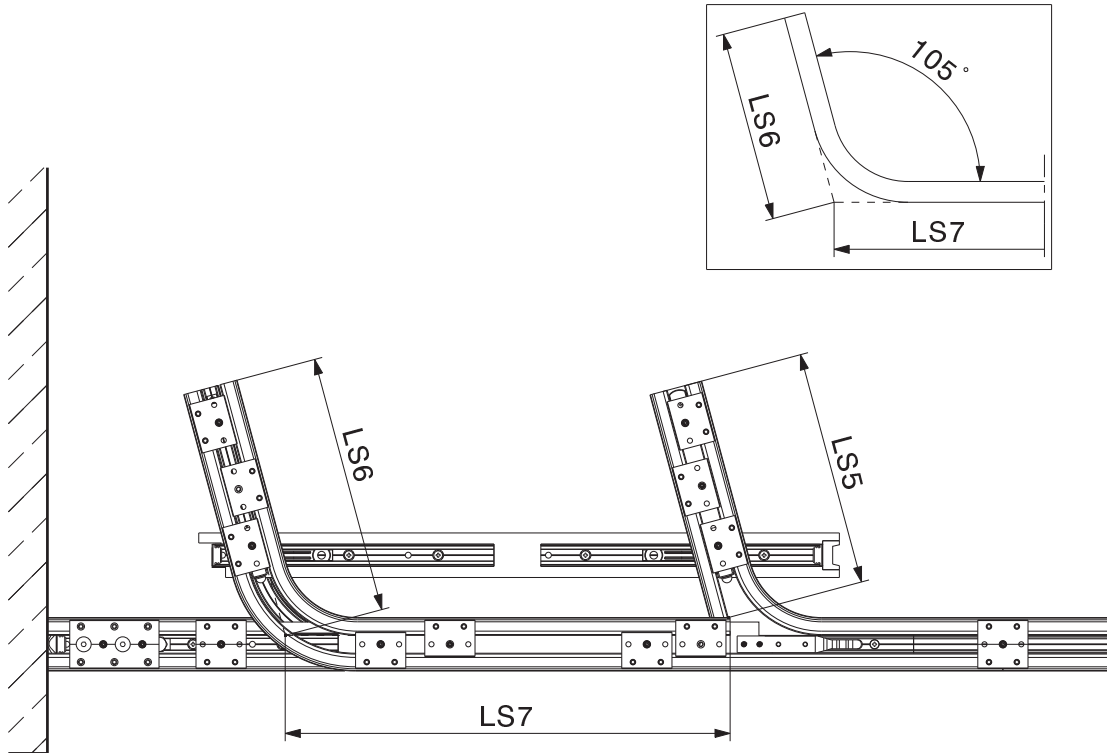

AM =	
LS3 =	
LS4 =	

siehe Seite 6-8
 voir pages 6-8
 see pages 6-8
 vedi pagine 6-8
 ver páginas 6-8

LS5 = LS4 - 21	
LS6 = LS3 - 25	
LS7 = AM - 21	

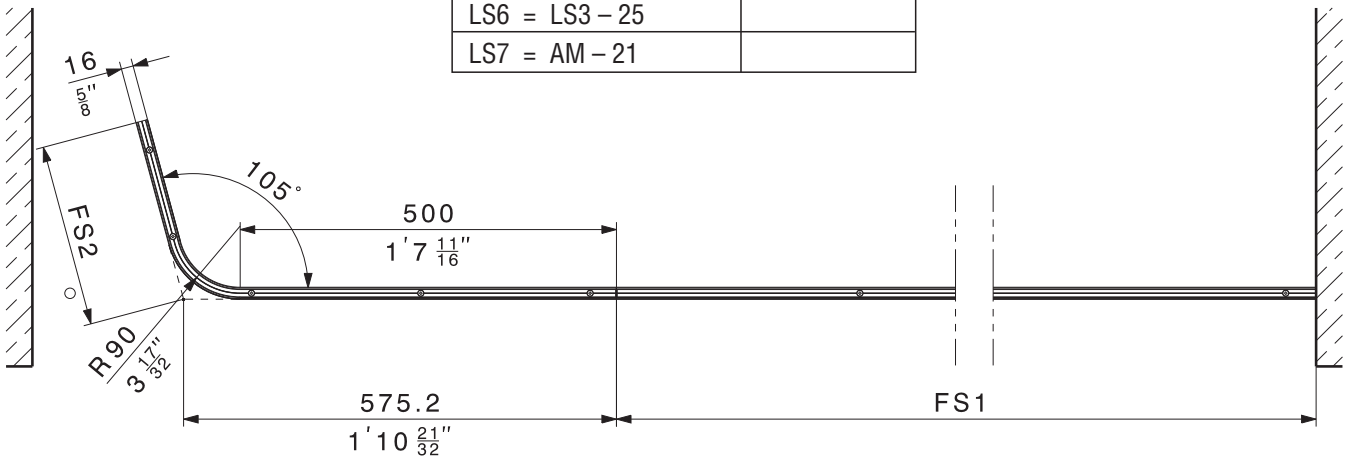

LS =	Laufschiene Rail de roulement Top track Binario Riel de rodadura
FS =	Führungsschiene Rail de guidage Bottom guide channel Guida Riel de guía

FS1 = LS1 + 230	
FS2 = LS3 - 13	

Technische Änderungen vorbehalten
 Sous réserve de modifications techniques
 Subject to modification

Con riserva di apportare modifiche tecniche
 Bajo reserva de modificaciones técnicas

Komponenten Schiebetüren
Composants des portes coulissantes
Components sliding doors
Componenti porte scorrevoli
Componentes paneles deslizantes

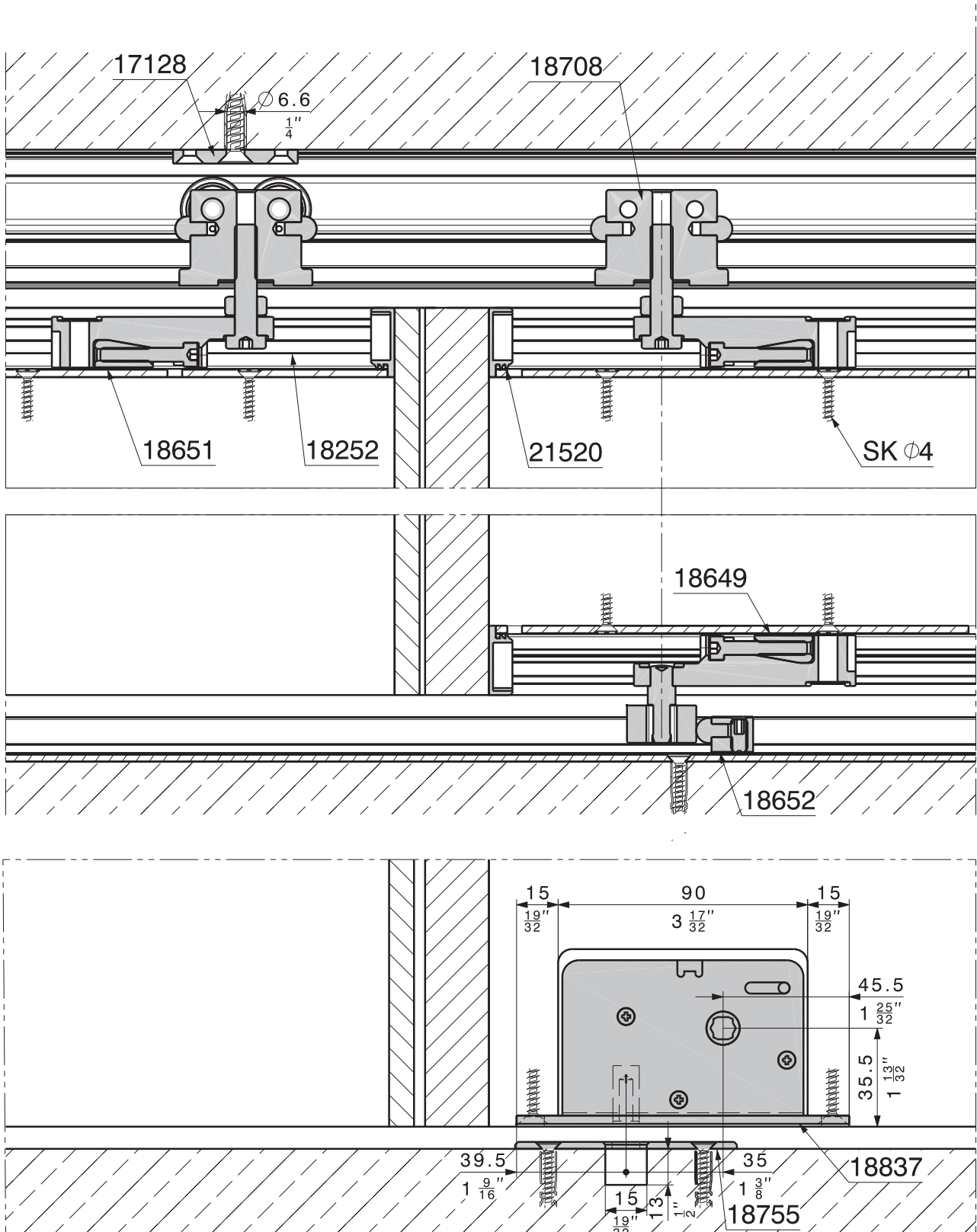

Technische Änderungen vorbehalten
 Sous réserve de modifications techniques
 Subject to modification

Con riserva di apportare modifiche tecniche
 Bajo reserva de modificaciones técnicas

Komponenten Drehtüren
Composants des portes pivotantes
Components pivot doors
Componenti porte girevoli
Componentes puertas pivotantes

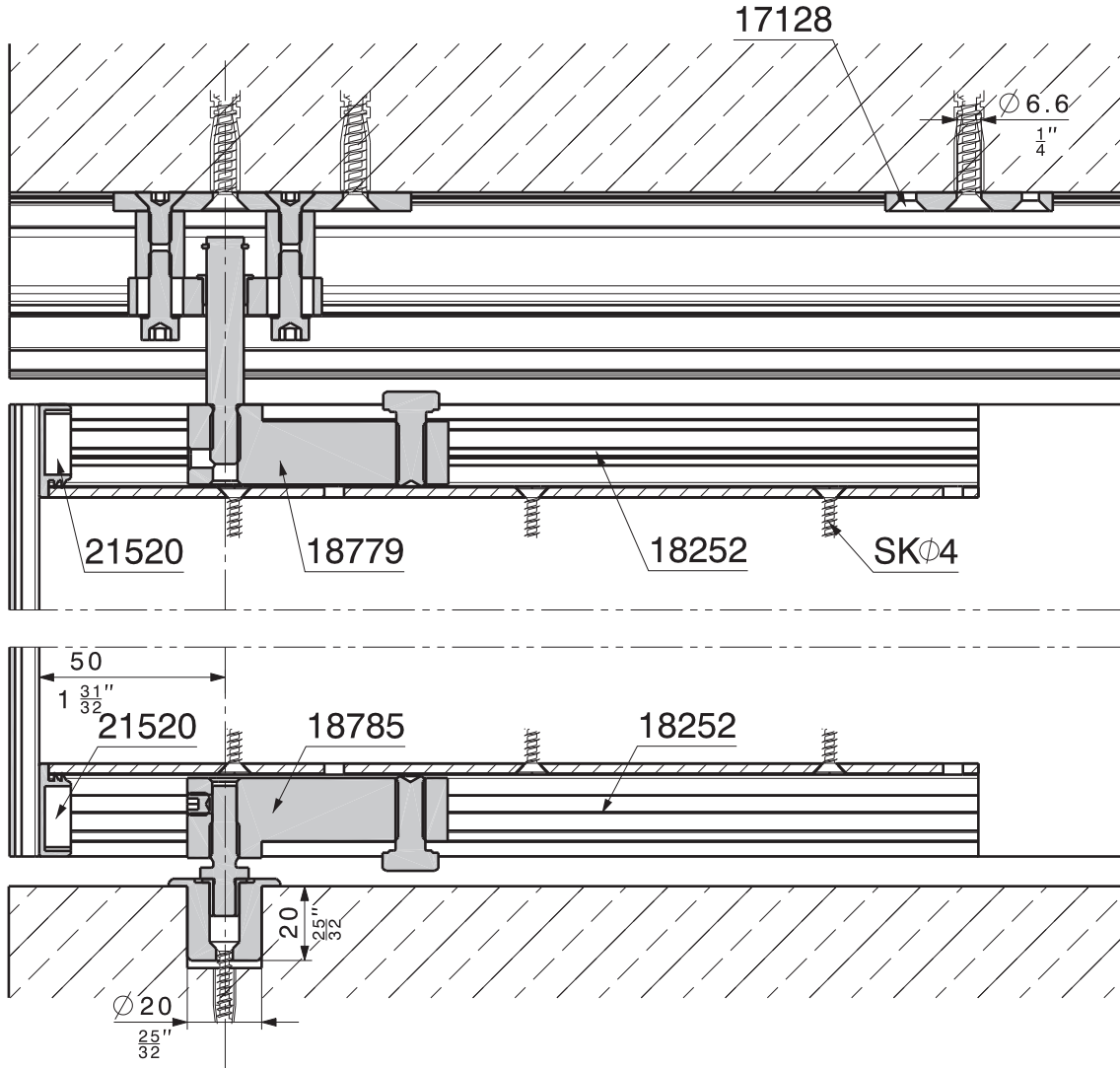

Technische Änderungen vorbehalten
 Sous réserve de modifications techniques
 Subject to modification

Con riserva di apportare modifiche tecniche
 Bajo reserva de modificaciones técnicas

Position Bolzenriegelschloss mit Führungszapfen
Position de la serrure à pènes avec goujon de guidage
Position of bar bolt lock with guide pin
Posizione serratura a chiavistello con perno di guida
Posición cerradura de pasador con perno de guía

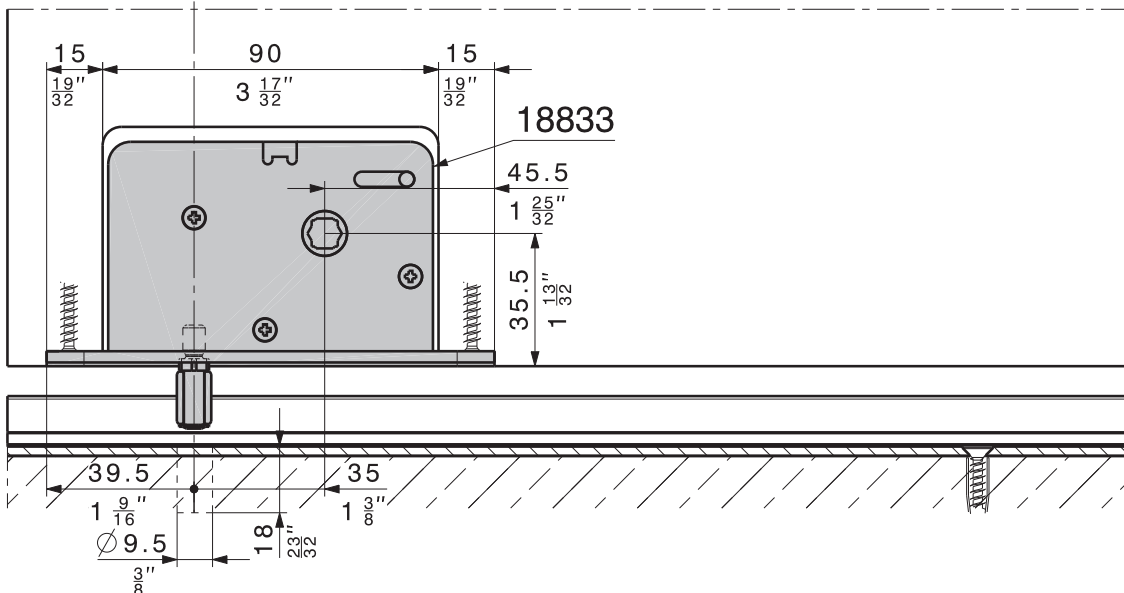
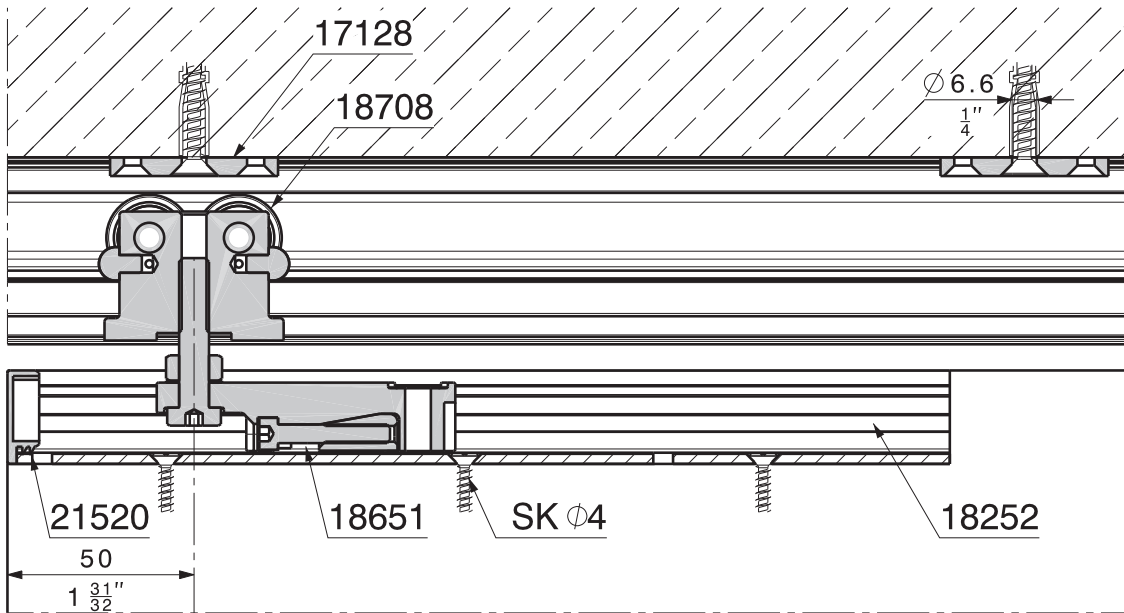
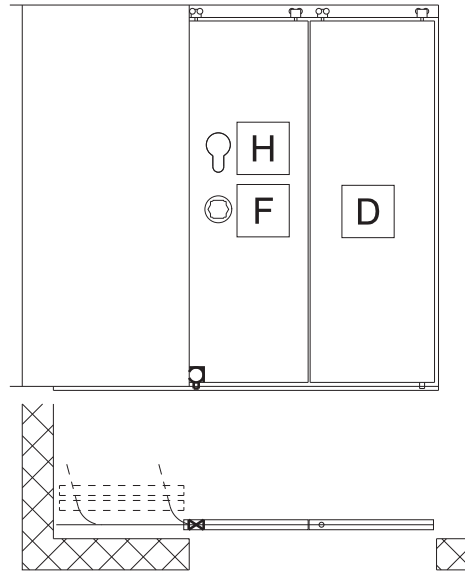

Ausfräsungen Schiebetüren
Découpages des portes coulissantes
Cutouts sliding doors
Fresature porte scorrevoli
Fresados paneles deslizantes

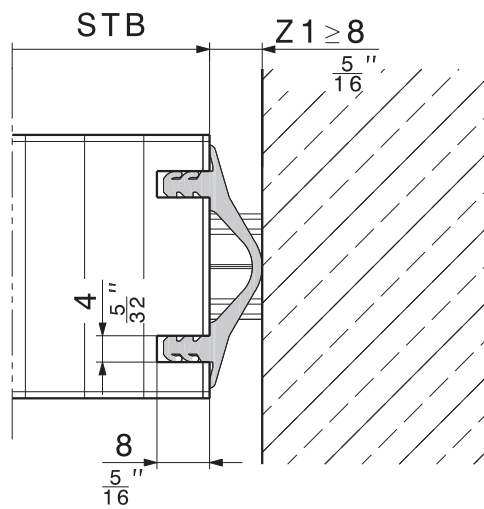
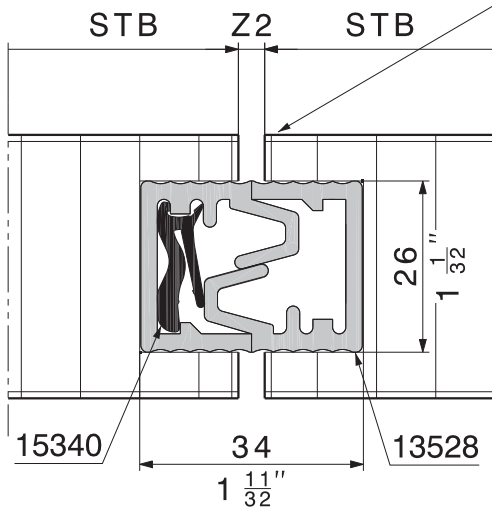
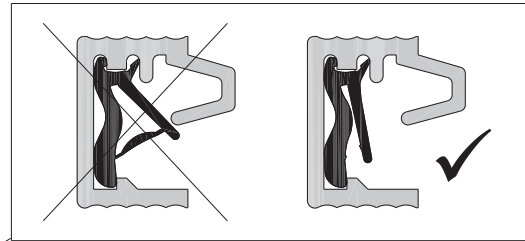
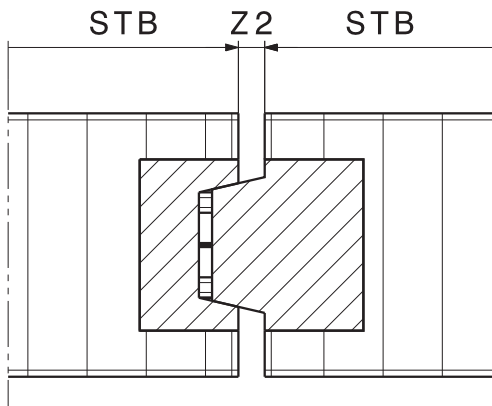
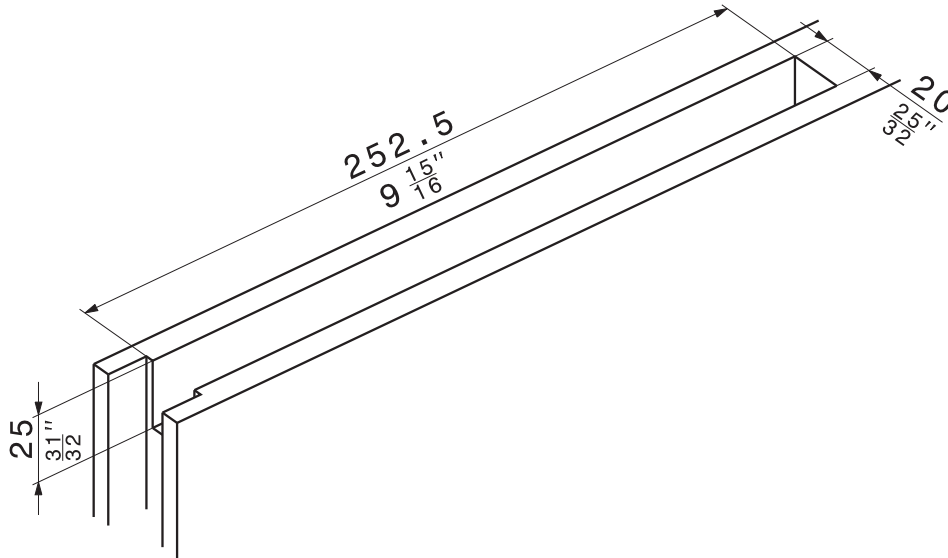

Montage der Führungsschienen
Montage des rail de guidage
Mounting of bottom guide channels
Montaggio delle guide
Montaje de los rieles de guía

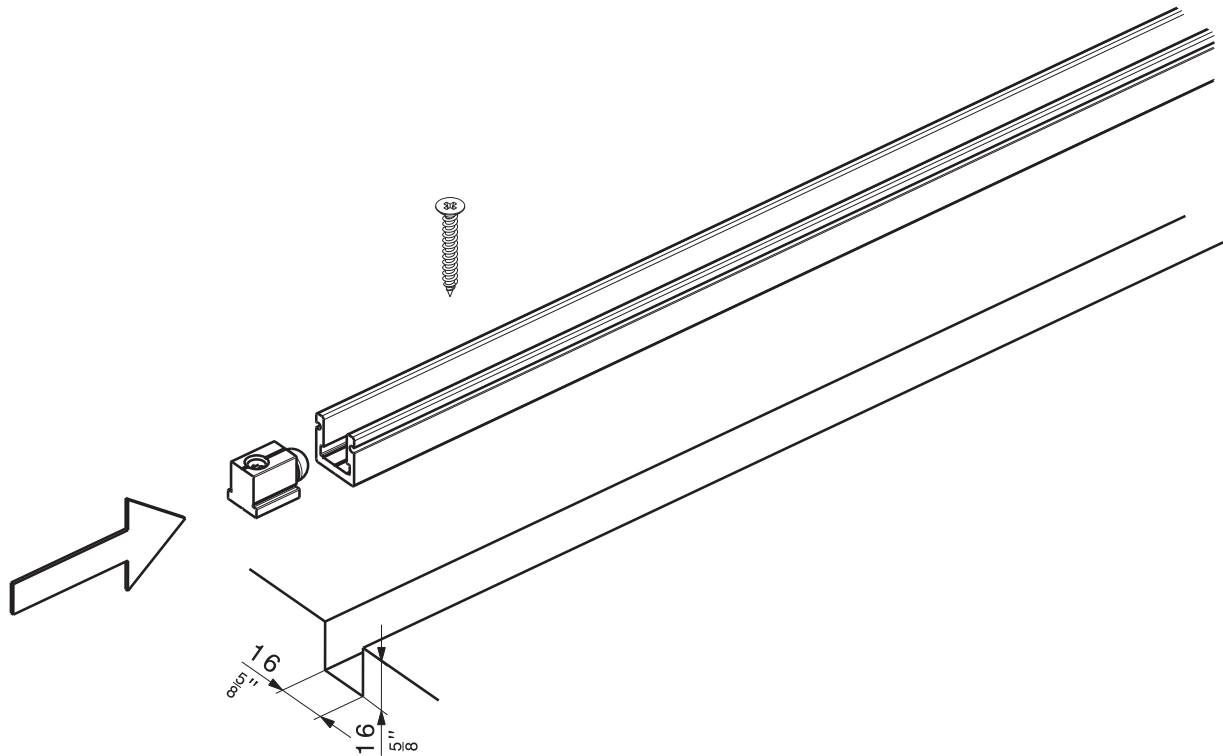

Technische Änderungen vorbehalten
Sous réserve de modifications techniques
Subject to modification

Con riserva di apportare modifiche tecniche
Bajo reserva de modificaciones técnicas

Montage der Laufschienen
Montage des rails de roulement
Mounting of top tracks
Montaggio dei binari
Montaje de los rieles de rodadura

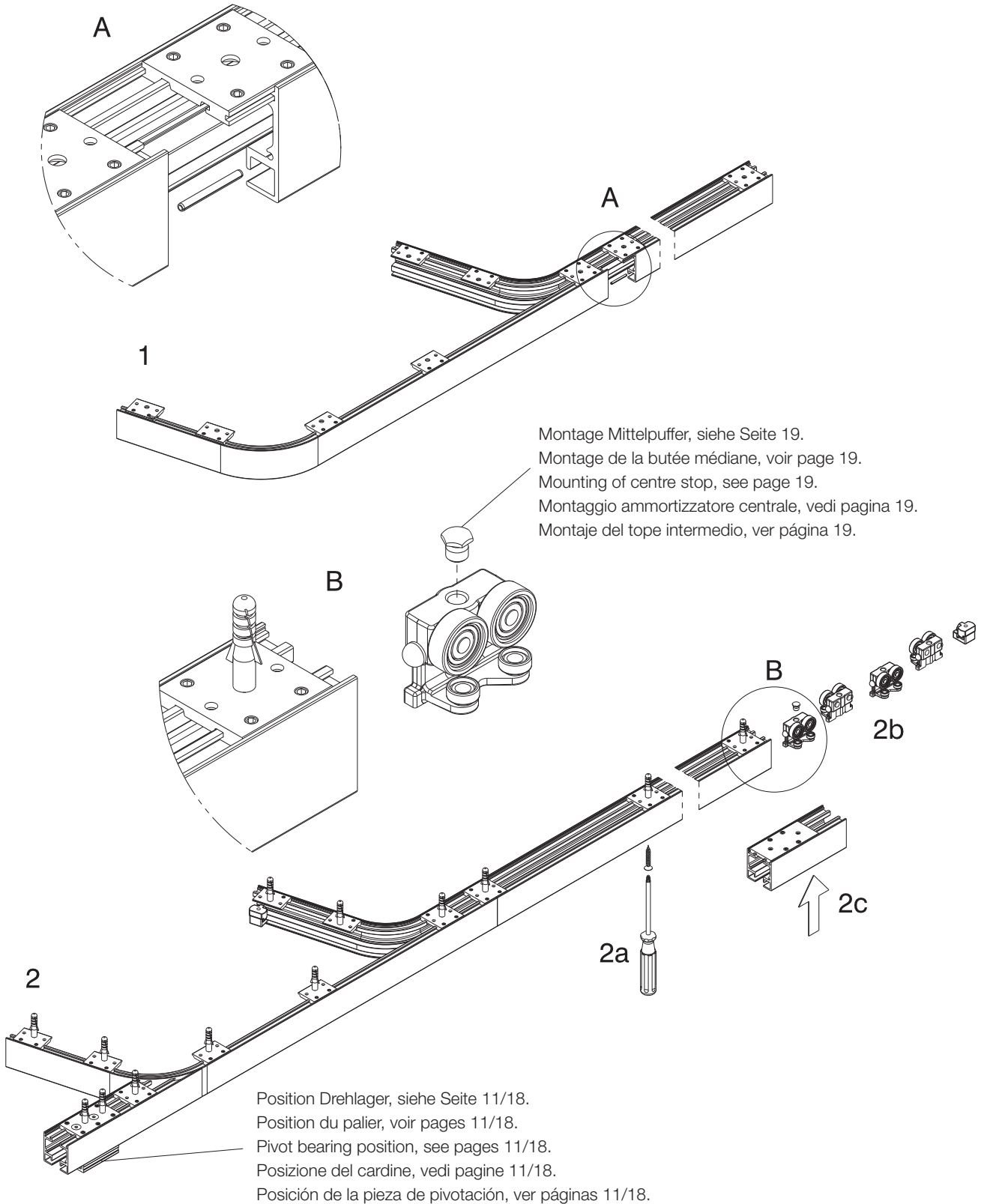

Technische Änderungen vorbehalten
 Sous réserve de modifications techniques
 Subject to modification

Con riserva di apportare modifiche tecniche
 Bajo reserva de modificaciones técnicas

Montage Stapelraum-Innenverblendung
Montage de cache intérieur pour espace de parcage
Mounting of the stacking area inside covers
Montaggio zona di stipa-rivestimento interno
Montaje del área de apilado con perfil de cobertura a la vista

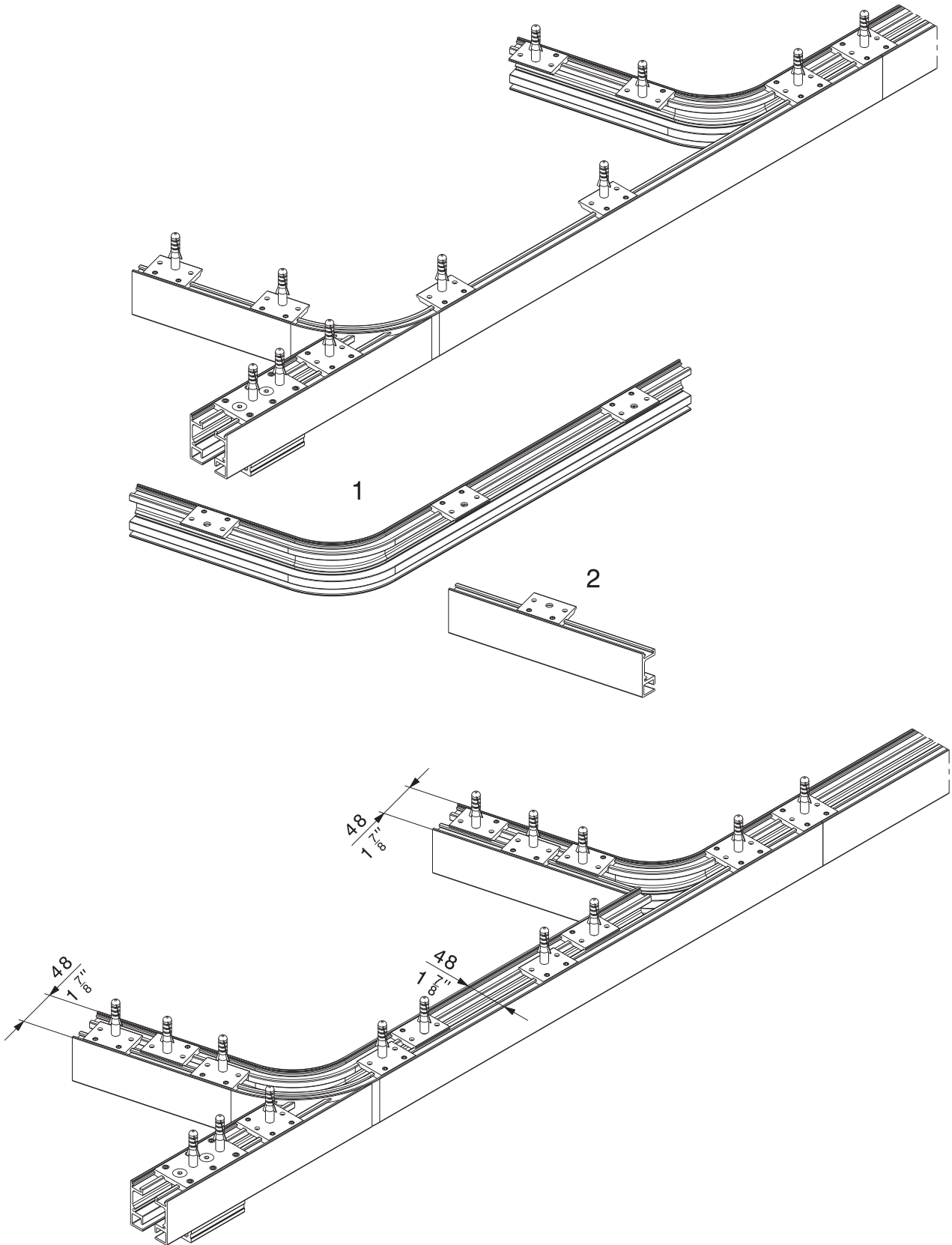

Technische Änderungen vorbehalten
Sous réserve de modifications techniques
Subject to modification

Con riserva di apportare modifiche tecniche
Bajo reserva de modificaciones técnicas

Montage der Schiebetüre
Montage de la porte coulissante
Mounting of sliding door
Montaggio della porta scorrevole
Montaje del panel deslizando

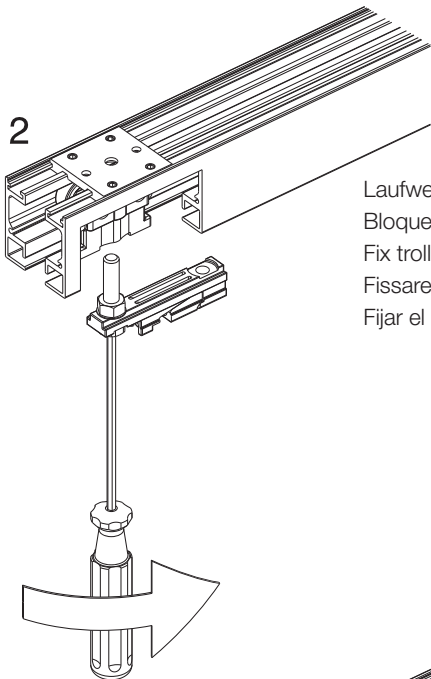
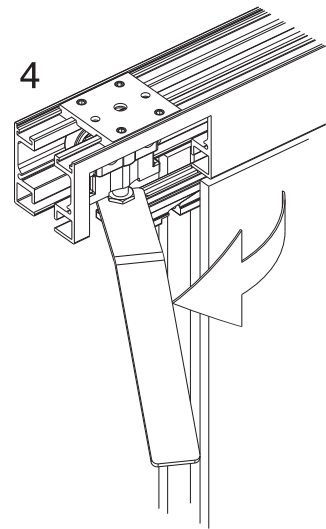
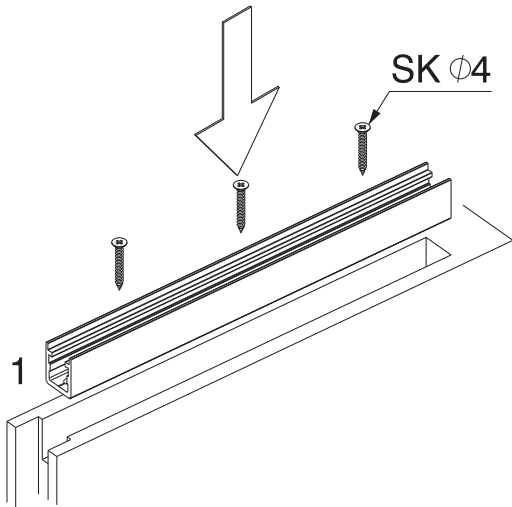

Laufwerk und Bodenführung fixieren, wenn sich die Türen im Stapelraum befinden.
 Bloquer chariot et guide inférieur lorsque les portes se trouvent dans l'espace de parcage.
 Fix trolley and bottom guide when the doors are in the parking area.
 Fissare il carrello e la guida sul pavimento, quando le porte si trovano nel parcheggio.
 Fijar el carro y la guía inferior cuando los paneles se encuentran en el área de apilado.

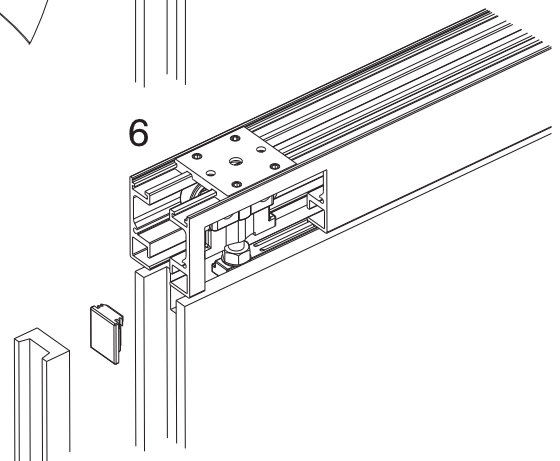
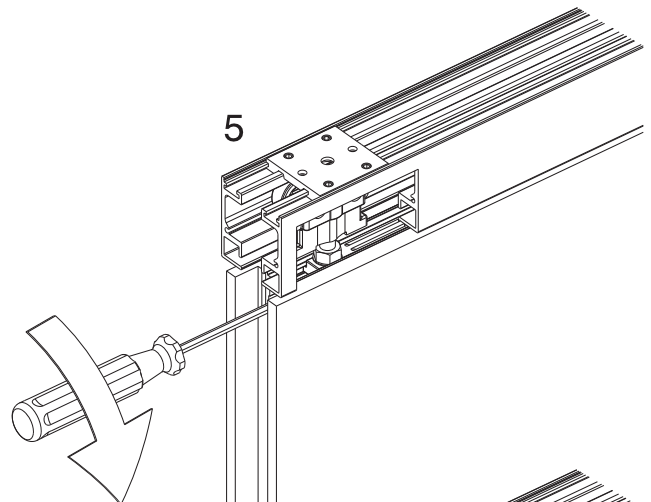
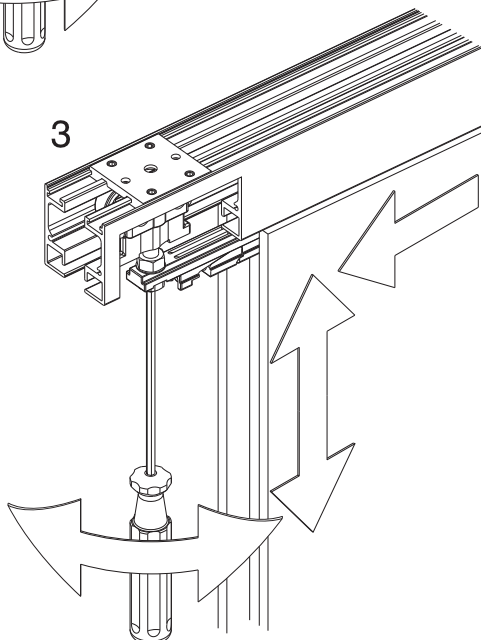

Montage der Drehtüre
Montage de la porte pivotante
Mounting of pivot door
Montaggio della porta girevole
Montaje de la puerta pivotante

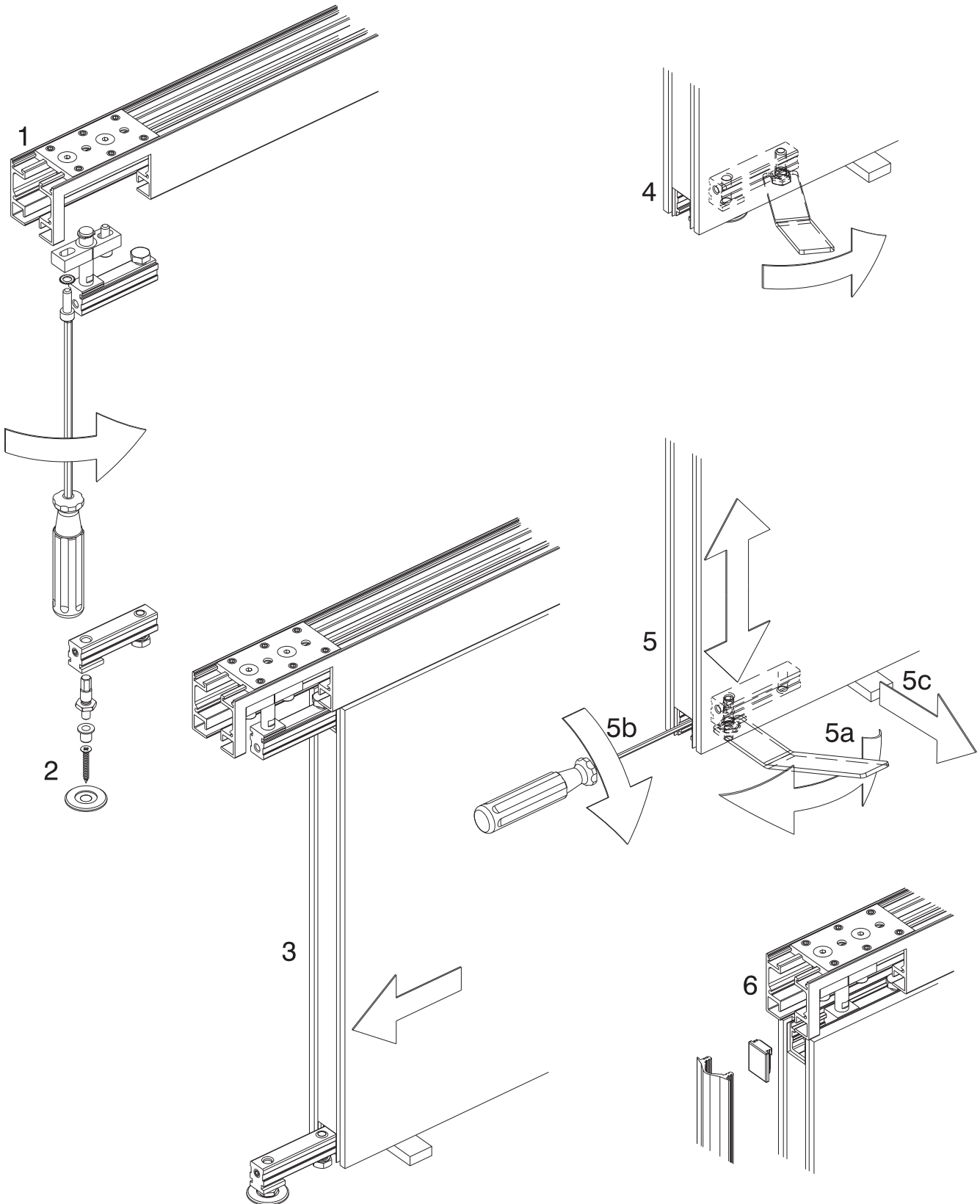



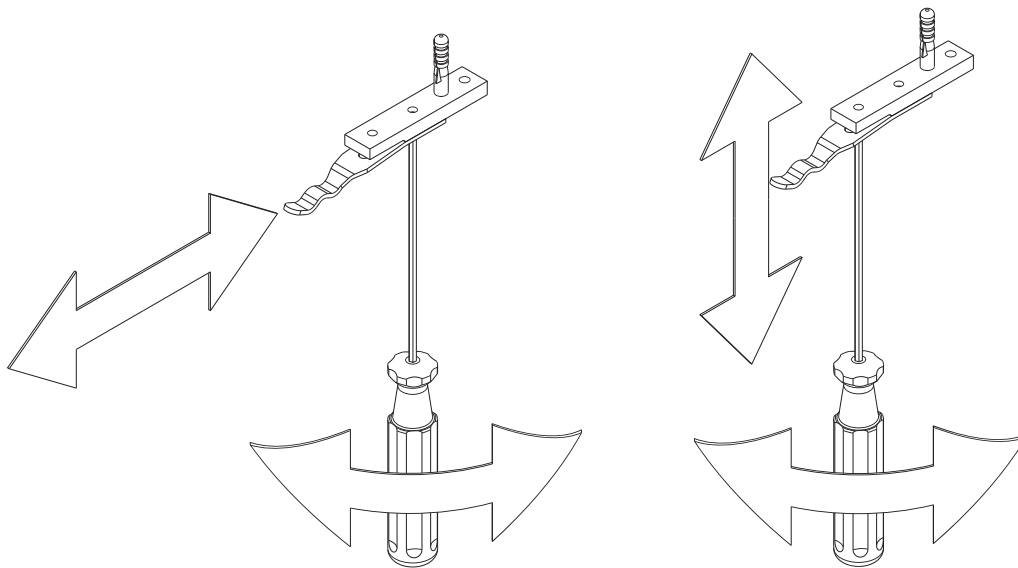
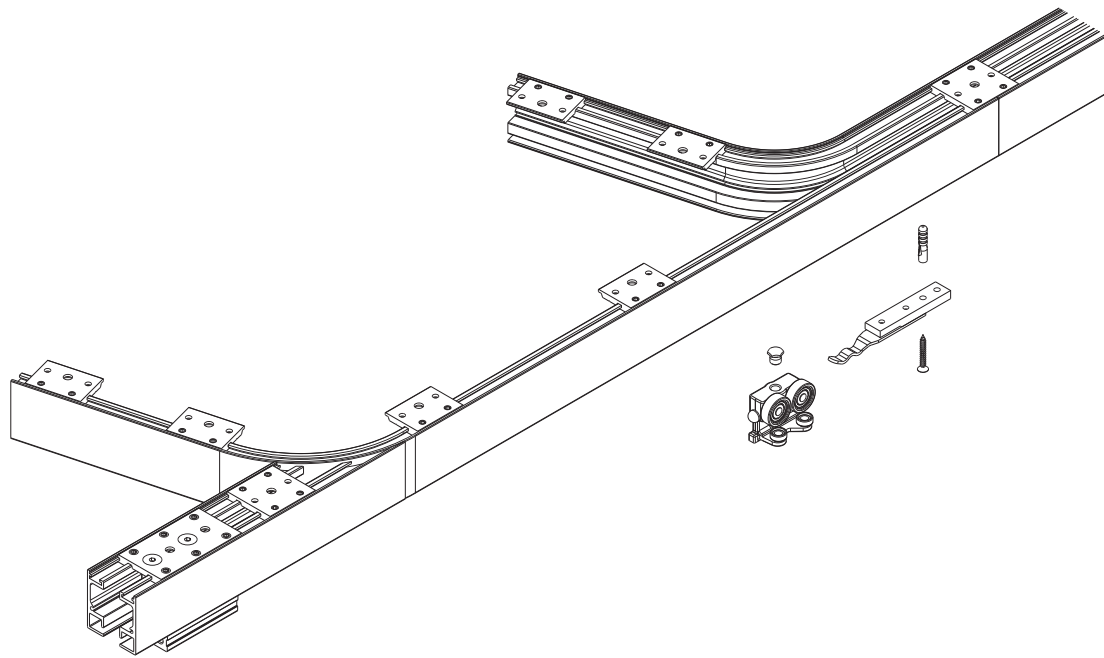

Montage Mittelpuffer
Montage de la butée médiane
Mounting of centre stop
Montaggio paracolpi centrale
Montaje del tope intermedio





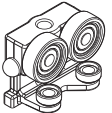
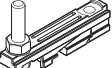

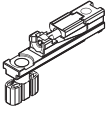
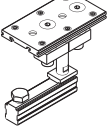
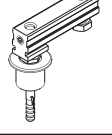
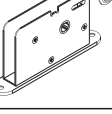
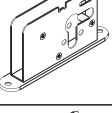
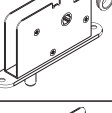
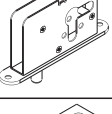
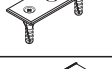



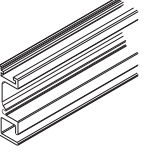
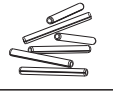

Technische Änderungen vorbehalten
Sous réserve de modifications techniques
Subject to modification

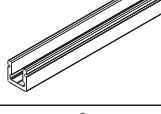
Con riserva di apportare modifiche tecniche
Bajo reserva de modificaciones técnicas

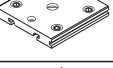
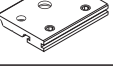
Beschlägeübersicht
Composants de la ferrure
Hardware system components
Assortimento ferramenta
Componentes de los herrajes

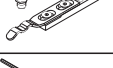
		18708
		18651
	250 mm (9 ²⁷ / ₃₂ "	18252
		21520
		18649
		18779
		18785
	4/6kt 7/8 mm	18837
	PZ 17 mm	18836
	4/6kt 7/8 mm FZ	18833
	PZ 17 mm FZ	18750
		18755
	150 mm (5 ²⁹ / ₃₂ "	19160

	75° 580 mm (1'10 ²⁷ / ₃₂ "	17289
	75° 580 mm (1'10 ²⁷ / ₃₂ "	17290
	2500 mm (8'2 ⁷ / ₁₆ "	17795
	3500 mm (11'5 ¹³ / ₁₆ "	17796
	6000 mm (19'8 ⁷ / ₃₂ "	16891
	nach Mass sur mesure cut to size su misura a medida	17529
	3 x 30 mm (¹ / ₈ " x 1 ³ / ₁₆ "	17221
	500 mm (1'7 ¹¹ / ₁₆ "	18748
	6000 mm (19'8 ⁷ / ₃₂ "	18216
	3500 mm (11'5 ¹³ / ₁₆ "	18864
	2 x 20 mm (³ / ₃₂ " x ²⁵ / ₃₂ "	18640
		17128
		17749
		19165
		18652
		17283
		18751
		19128