

# ATHMER PIRKSTU AIZSARGPROFILI EŅĢU PUSĒ - BO

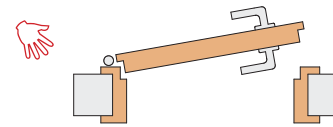

**Profila garums 1950 mm**  
**Profil length 1950 mm**

**Kompl. iekļauts /**  
**scope of supply**

**Piegriešana /**  
**cutting**

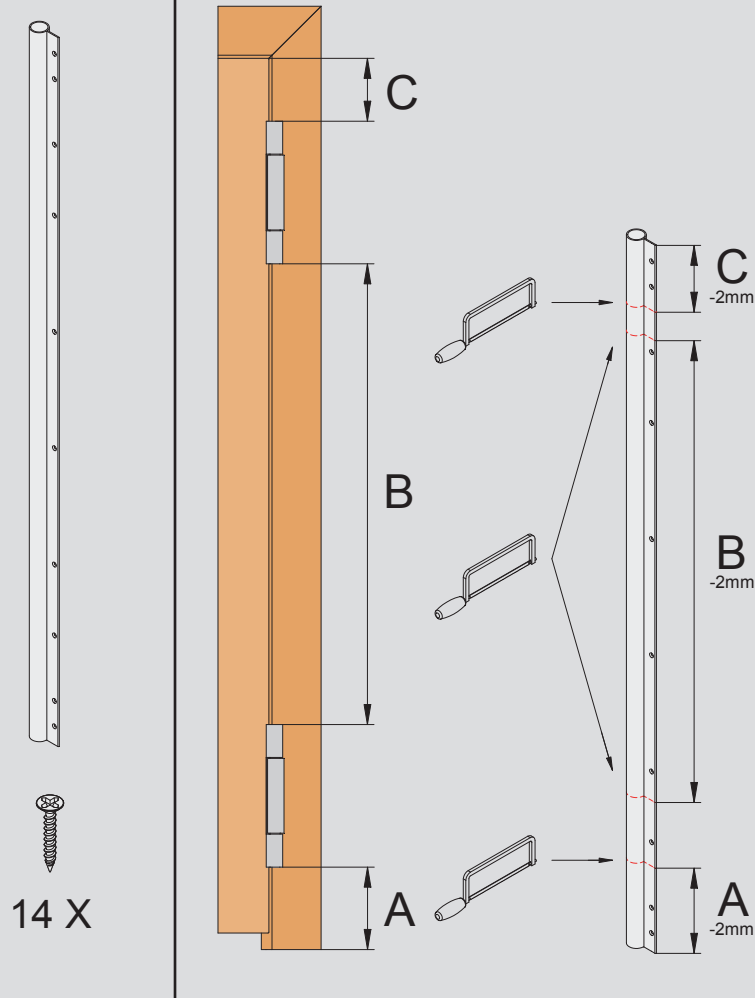

**Kompl. 3-daļ.**  
**Set 3-pcs.**

**Kompl. iekļauts /**  
**scope of supply**



**Montāža /**  
**assembly**

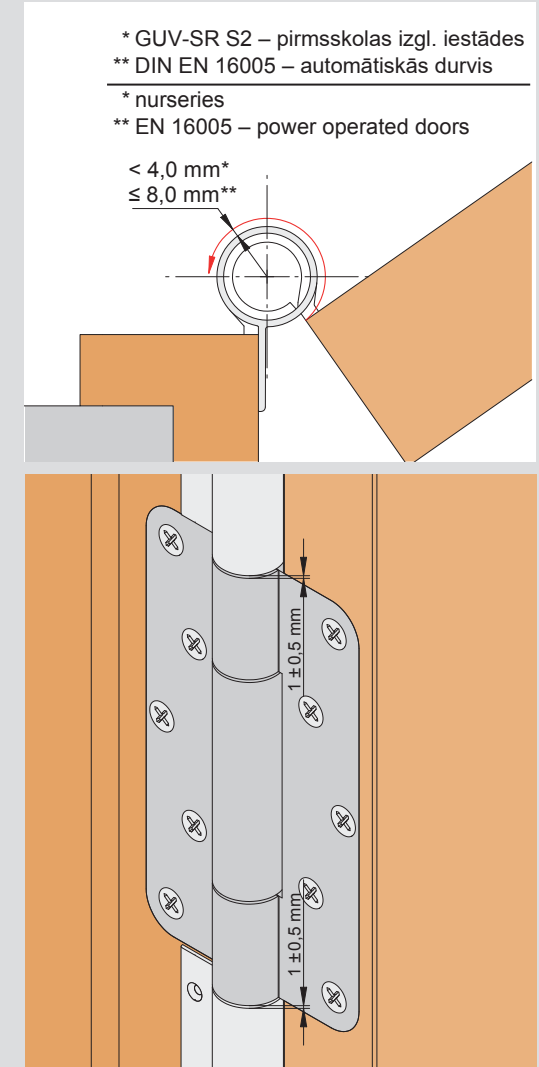
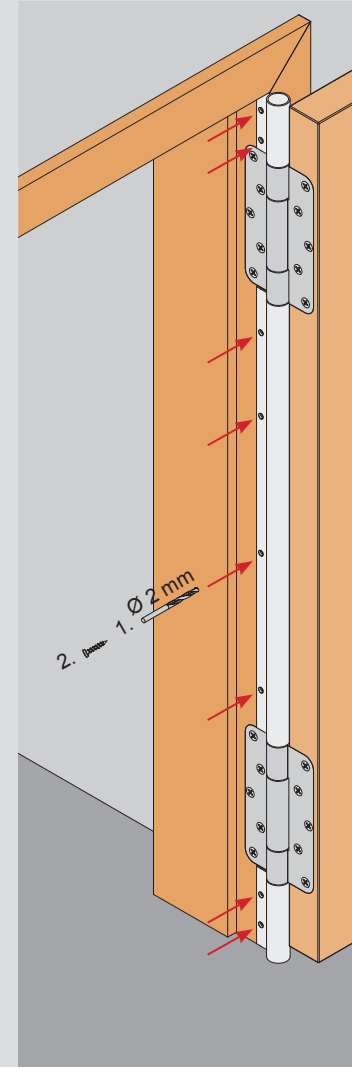

\* GUV-SR S2 – pirmsskolas izgl. iestādes  
\*\* DIN EN 16005 – automātiskās durvis

\* nurseries  
\*\* EN 16005 – power operated doors

Bitte beachten Sie die alternativen Einbausituationen in den Anwendungsbeispielen. Der Einsatz von Fingerschutz entbindet nicht von der Aufsichtspflicht. Technische Änderungen vorbehalten.  
Please note the alternative installation situations in the application examples. The use of finger protection does not obviate the duty of supervision. Technical specifications are subject to change.

# ATHMER PIRKSTU AIZSARGPROFILI EŅĢU PUSĒ - BO

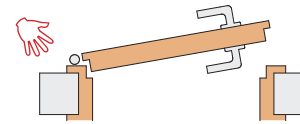

**Profila garums 1750 mm**  
**Profil length 1750 mm**

**Kompl. iekļauts /**  
**scope of supply**

**Piegriešana /**  
**cutting**



7 X

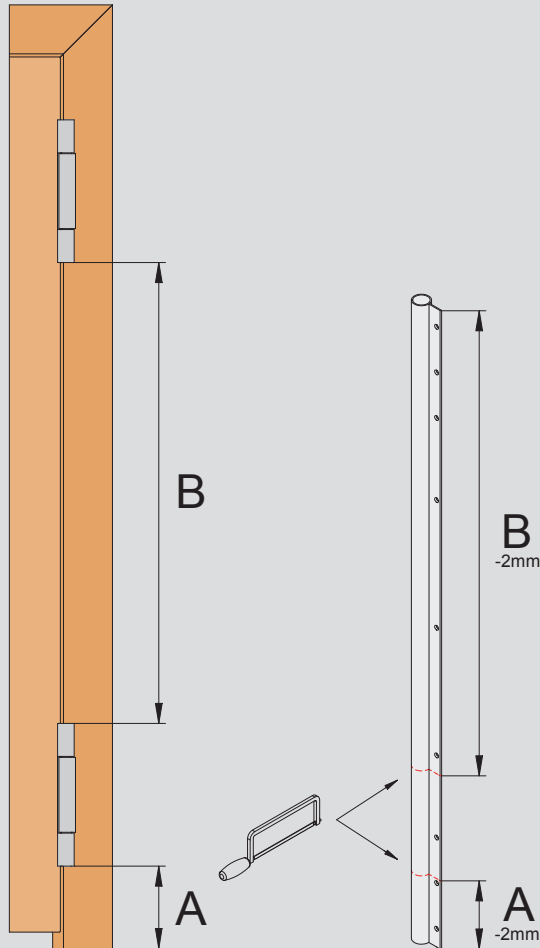

**Kompl. 2-daļ.**  
**Set 2-pcs.**

**Kompl. iekļauts /**  
**scope of supply**



7 X

**Montāža /**  
**assembly**

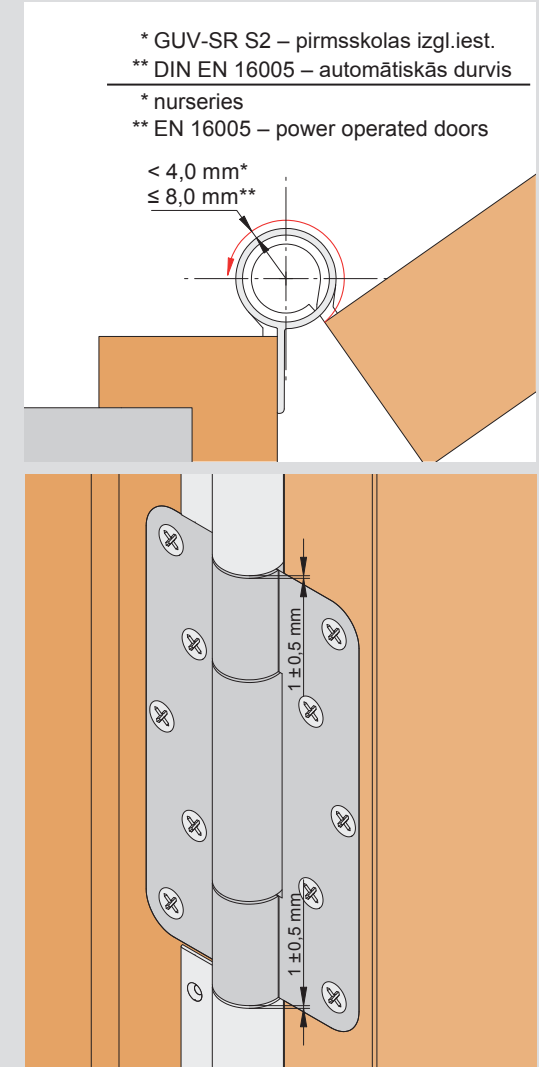
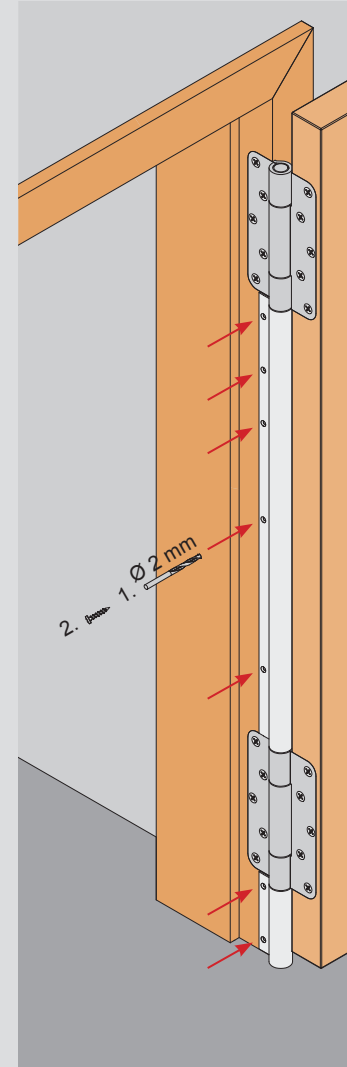

\* GUV-SR S2 – pirmsskolas izgl.iest.  
\*\* DIN EN 16005 – automātiskās durvis  
\* nurseries  
\*\* EN 16005 – power operated doors

< 4,0 mm\*  
≤ 8,0 mm\*\*

Bitte beachten Sie die alternativen Einbausituationen in den Anwendungsbeispielen. Der Einsatz von Fingerschutz entbindet nicht von der Aufsichtspflicht. Technische Änderungen vorbehalten.  
Please note the alternative installation situations in the application examples. The use of finger protection does not obviate the duty of supervision. Technical specifications are subject to change.